

HERZ Motorised flow controller 4006

Control and regulating valve

Standard specification sheet

4006

Issue 0610

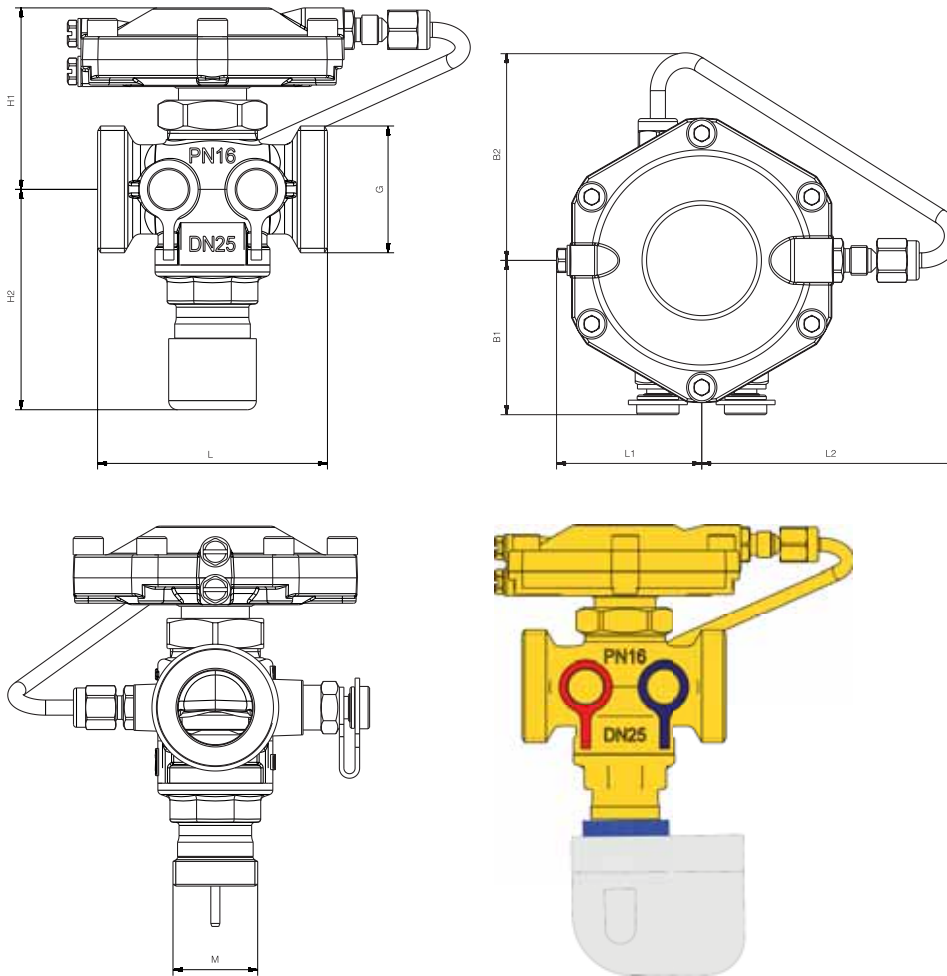

Dimensions in mm

	DN	G	L	H1	H2	H2 + Actuator	B1	B2	L1	L2	M
1 4006 11	15	3/4 G	66	59	73	134	49	63	48	81	28 x 1,5
1 4006 12	20	1 G	76	60	73	134	51	68,5	48	85	28 x 1,5
1 4006 13	25	5/4 flatsealing	76	60	73	134	51	68,5	48	85	28 x 1,5
1 4006 14	32	1½ flatsealing				140					28 x 1,5
1 4006 15	40	1¾ flatsealing	132	86	95	156	75	47	70	81	28 x 1,5
1 4006 16	50	2¾ flatsealing	140	86	95	156	75	47	70	81	28 x 1,5

Maximum operating pressure	16 bar
Test pressure	
Maximum differential pressure on the body	4 bar
Minimum operating temperature	2 °C (pure water)
Minimum operating temperature	- 20 °C (frost protection)
Maximum operating temperature	100 °C
Lift	4 mm

The integrated control unit together with the actuating drive is responsible for modular control. Various actuating drives might be used (see also chapter: Accessories and spare parts).

Technical data

We reserve the right to make changes resulting from HERZ's ongoing development policy.

HERZ Armaturen

Richard-Strauss-Straße 22 • A-1230 Wien
e-mail: office@herz-armaturen.com • www.herz-armaturen.com



The combination valve is used in all heating and cooling systems with circulation pumps. The valve automatically maintains flow to the required part of the system at the set rate by measuring and immediately adjusting to any variation in pressure. No additional measurements are necessary and the correct quantity of water is supplied to all parts of the system under all operating conditions. The combination valve maintains the flow at a constant rate that has been preset; the diaphragm responds to the pressure upstream and downstream of the regulating valve; the valve settings directly refer to the volume flow; accordingly, the maximum volume flow is preset directly according to the diagram when the valve is fitted. Thus systems such as heating or cooling systems, ceiling heating or cooling systems and floor heating systems may be controlled easily even if the pressure within the system varies. In addition to the flow rate controller, angled STRÖMAX valves (4115 A) must be fitted in the corresponding flow pipe. If control measurements of the flow rate are required, then STRÖMAX-M valves (4017 M, 4117 M, 4217 GM) must be fitted instead.

Application

Body: dezincification-resistant brass
 Membranes and O-rings: EPDM
 Water purity in accordance with the ÖNORM H 5195 and VDI 2035 standards
 Ethylene and propylene glycol can be mixed to a ratio of 15 - 45 vol. [%].

Materials

The valve is fitted in the return in any orientation. The arrow on the valve body should align with the direction of flow.

Installation

It is recommended that an isolation valve is fitted both upstream and downstream of the combination valve.

The combination valve may be isolated using the HERZ pre-setting key (1 4006 02). For pre-setting, turn the key right (clockwise) up to the stop. The setting should then read < 0%.

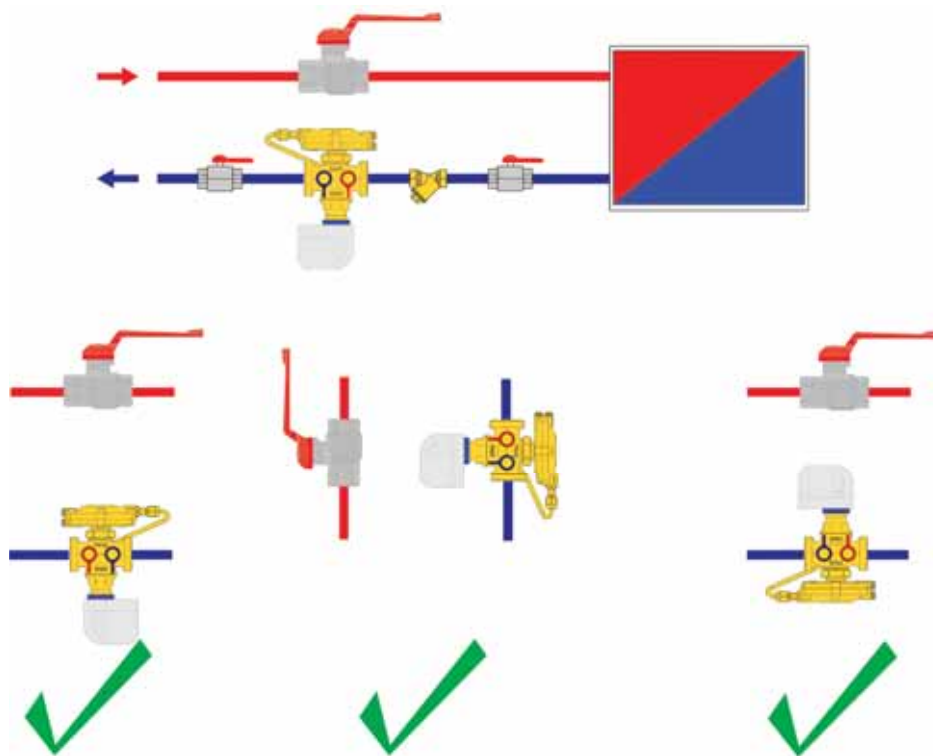

DN 15	0,4 m³/h	DN 32	2,5 m³/h
DN 20	0,9 m³/h	DN 40	5 m³/h
DN 25	1,9 m³/h	DN 50	5 m³/h

k_{vs}-values

- 1 **4117** .. HERZ-STRÖMAX circuit control valves, angle version
- 1 **4217** .. HERZ- STRÖMAX circuit control valves, straight version
- 1 **4017** .. HERZ- STRÖMAX circuit control valves with integrated metering orifice plate
- 1 **4125** .. HERZ shut-off valves, angle version
- 1 **4115** .. HERZ shut-off valves, angle version
- 1 **4215** .. HERZ shut-off valves, straight version, also variants with male threads. For details please refer to the corresponding data sheets.
- 1 **0284** 01 test point for HERZ circuit control valve, blue cap (return)
- 1 **0284** 02 test point for HERZ circuit control valve, red cap (flow)
- 1 **0284** 11 test point for HERZ circuit control valve, extended model, blue cap (return)
- 1 **0284** 12 test point for HERZ circuit control valve, extended model, red cap (flow)
- 1 **0284** 21 HERZ test point with draining function, blue cap (return)
- 1 **0284** 22 HERZ test point with draining function, red cap (flow)
- 1 **0284** 00 test point adapter set
- 1 **7709** .. HERZ actuating drive for two-point or pulse control
- 1 **7990** .. HERZ actuating drive for continuous control
- 1 **0273** 09 screw plug 1/4
- 1 **4006** 02 HERZ pre-setting key for flow rate controller

Accessories and spare parts

Junction press screw fitting		Order number
with flat seal	14 x 2 - G 3/4	P 7014 41
	16 x 2 - G 3/4	P 7016 41
	18 x 2 - G 3/4	P 7018 41
	20 x 2 - G 3/4	P 7020 41
	16 x 2 - G 1	P 7016 42
	18 x 2 - G 1	P 7018 42
	20 x 2 - G 1	P 7020 42
	26 x 3 - G 1	P 7026 42
	26 x 3 - G 1¼	P 7026 43
	32 x 3 - G 1¼	P 7032 43
	40 x 3.5 - G 1¼	P 7040 43
	32 x 3 - G 1½	P 7032 44
	40 x 3.5 - G 1½	P 7040 44
	50 x 4 - G 1½	P 7050 44
with cone seal	14 x 2 - G 3/4	P 7014 81
	16 x 2 - G 3/4	P 7016 81
	18 x 2 - G 3/4	P 7020 81
	20 x 2 - G 3/4	P 7020 81

Connections

Pipe		8	10	12	14	15	16	18	22
Valve		DN 15	DN 15	DN 15	DN 15	DN 15	DN 15	DN 15	DN 20
Nut G		3/4	3/4	3/4	3/4	3/4	3/4	3/4	1
Connection	with metallic seal	1 6274 18	1 6274 00	1 6274 01	1 6274 02	1 6274 03	1 6274 04	---	1 6273 01
Connection	with soft seal	---	---	1 6276 12	1 6276 14	1 6276 15	1 6276 16	1 6276 18	

Pipe connections (with cone seal) for metal pipes

Compression union for calibrated soft steel and copper pipes (for details please refer to the corresponding data sheets)

Pipe	10 x 1.3	12 x 2	14 x 2	15 x 2.5	16 x 2	16 x 2.2	17 x 2	17 x 2.5	18 x 2.5	18 x 2
Valve	DN 15		DN 15	DN 15	DN 15	DN 15	DN 15	DN 15	DN 15	DN 15
Nut G	3/4		3/4	3/4	3/4	3/4	3/4	3/4		1
Connection	1 6098 18		1 6098 02	1 6098 16	1 6098 03	1 6098 12	1 6098 04	1 6098 05	1 6098 06	1 6098 07

Pipe connections (with cone seal) for plastic pipes

Pipe	20 x 2	20 x 3.5	20 x 2.5	25 x 3.5	26 x 3
Valve	DN 15	DN 15	DN 15		
Nut G	3/4	3/4	3/4		
Connection	1 6098 08	1 6098 10	1 6098 11		
Valve	DN 15			DN 15	DN 15
Nut G				1	1
Connection	1 6198 12			1 6098 00	1 6098 01

Plastic pipe connections for PE-X, PB and aluminium composite pipes (for details please refer to the corresponding data sheets)

When installing soft steel or copper pipes with a pipe wall of 1 mm or less with compression unions, we recommend the use of support sleeves (order no.: 1 0674 xx). When installing plastic pipes, suitable calibration tools are needed. Please refer to our instruction manual. For proper installation use silicone oil to lubricate the thread of the locking nut or olive screw as well as the olive.

- 1 6220 .. Iron pipe connection, consisting of nut, seal and pipe nipple with male pipe thread
- 1 6236 .. Soldering connection, consisting of nut, seal and soldering nipple
- 1 6240 .. Welding connection, consisting of nut, seal and welding nipple
- 1 6210 .. Iron pipe connection consisting of nut, seal and pipe nipple with male pipe thread
- 1 6235 .. Soldering connection, consisting of nut, seal and soldering nipple

Connection elements

Considering how the fitting is used, clean workmanship is required. A HERZ strainer (4111) should be fitted to prevent impurities.

Tips

Two test points are fitted on the same side of the valve and factory sealed. Thanks to this arrangement they are easily accessible and measurement devices can be quickly fitted, no matter in what position the valve has been installed.

Test points

The valve setting is clearly shown in percent. The preset value can be easily adjusted. The preset flow rate controller can be isolated at any time or adjusted to the required flow rate.

Pre-setting



Fan coil system with pump and built-in differential pressure controller

Application examples

Two-point control

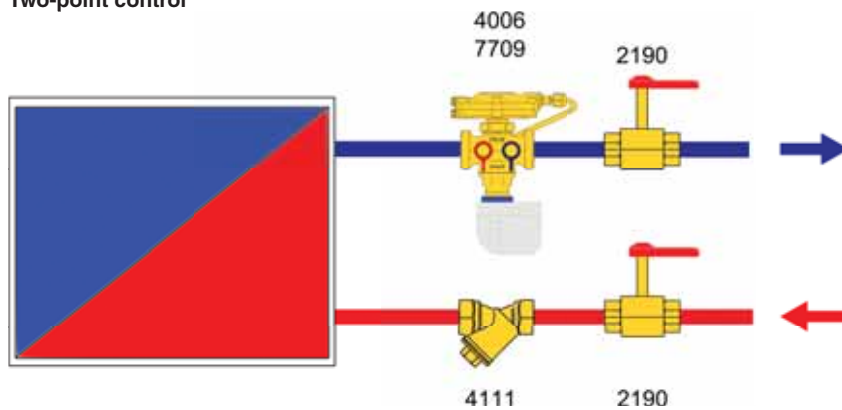

Modulating control

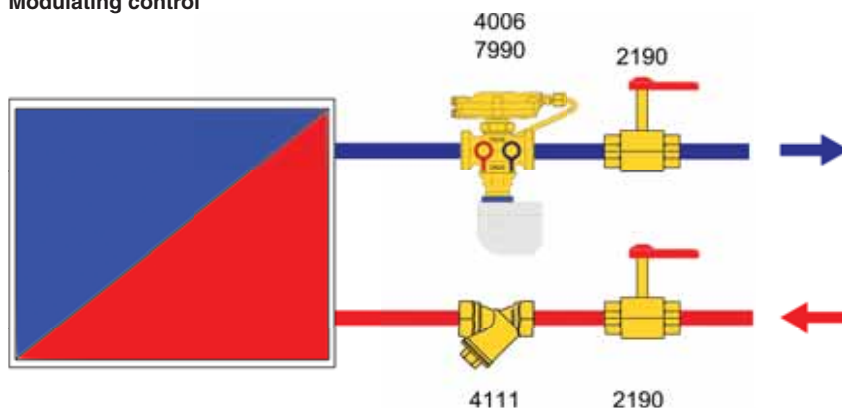

Two-point control

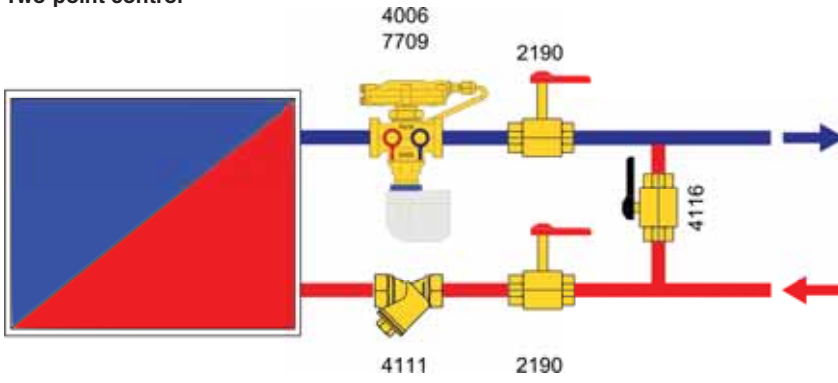

Modulating control

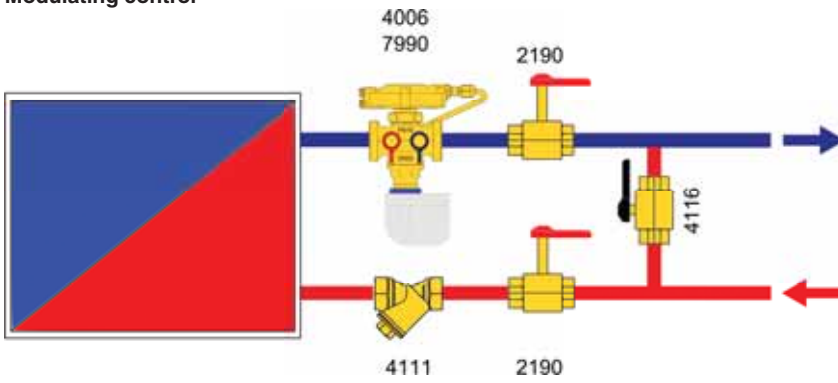

Please note: all diagrams are indicative in nature and do not claim to be complete.

All details contained in this brochure correspond to that available at the time of printing and are for information only. We reserve the right to make changes resulting from HERZ's ongoing development policy. The illustrations are understood to be indicative and may therefore vary visually from the actual products. Any differences in colour are due to the printing technology used. Products may also vary according to the country. We reserve the right to make changes to technical specifications and functions. For questions please contact your nearest HERZ office.

HERZ standard diagram

HERZ combination valve

Order no. **4006**

Dim. DN 15 - DN 50

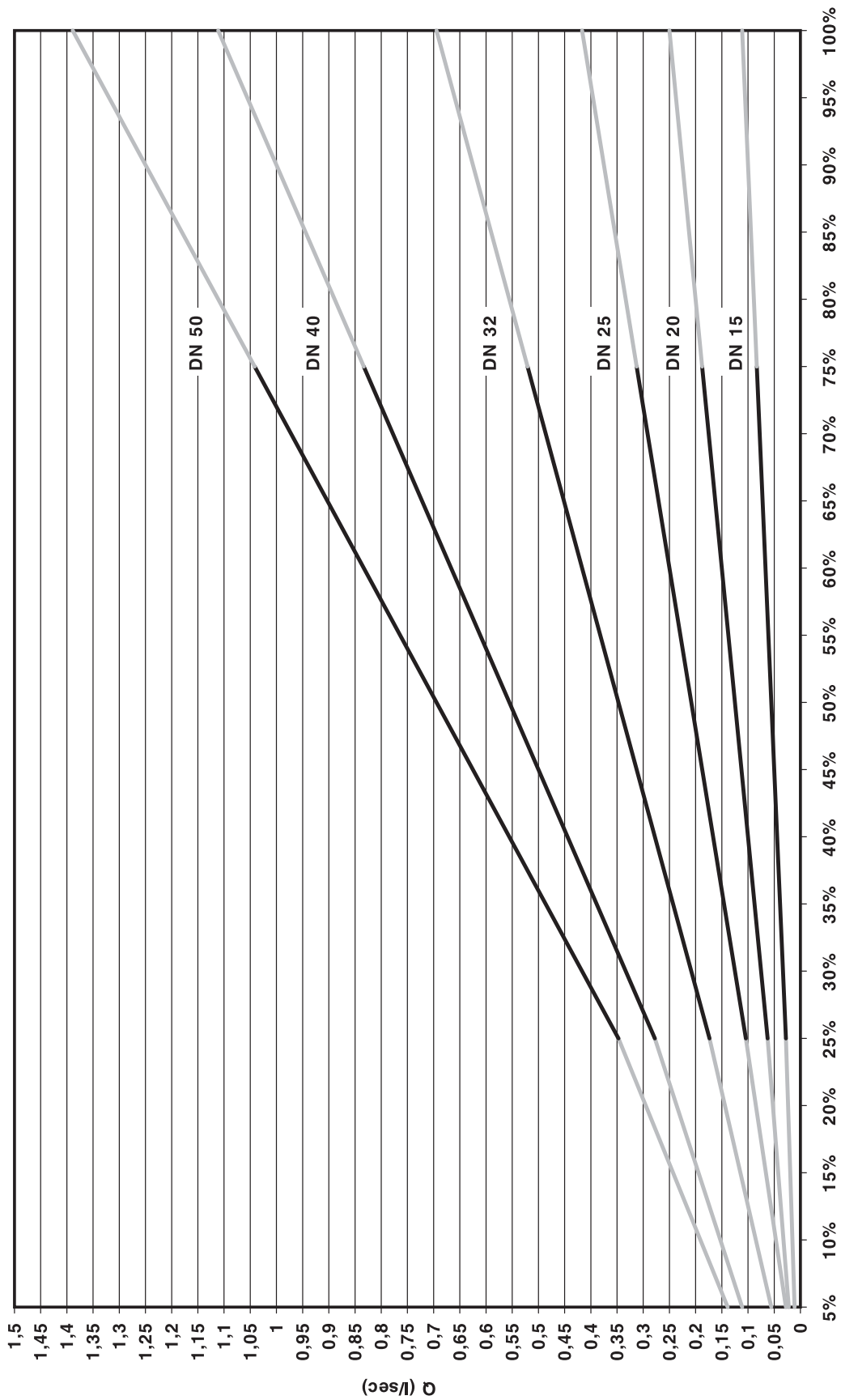

Änderungen vorbehalten.

HERZ standard diagram

Order no. 1 **4001** 21, 1 **4006** 11

DN 15

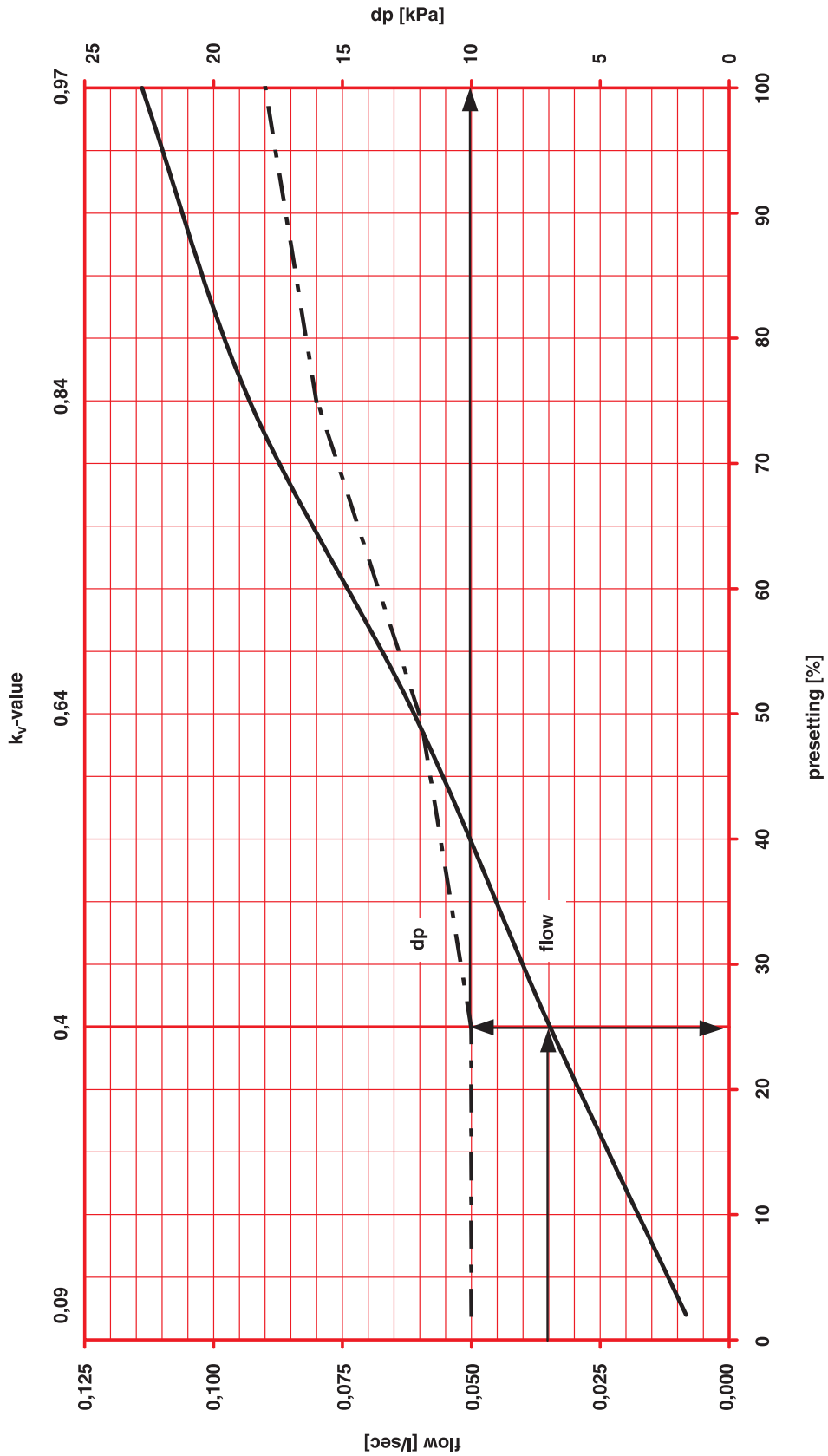

HERZ Armaturen

Richard-Strauss-Straße 22 • A-1230 Wien
 e-mail: office@herz-armaturen.com • www.herz-armaturen.com



HERZ standard diagram

Order no. 1 **4001** 22, 1 **4006** 12

DN 20

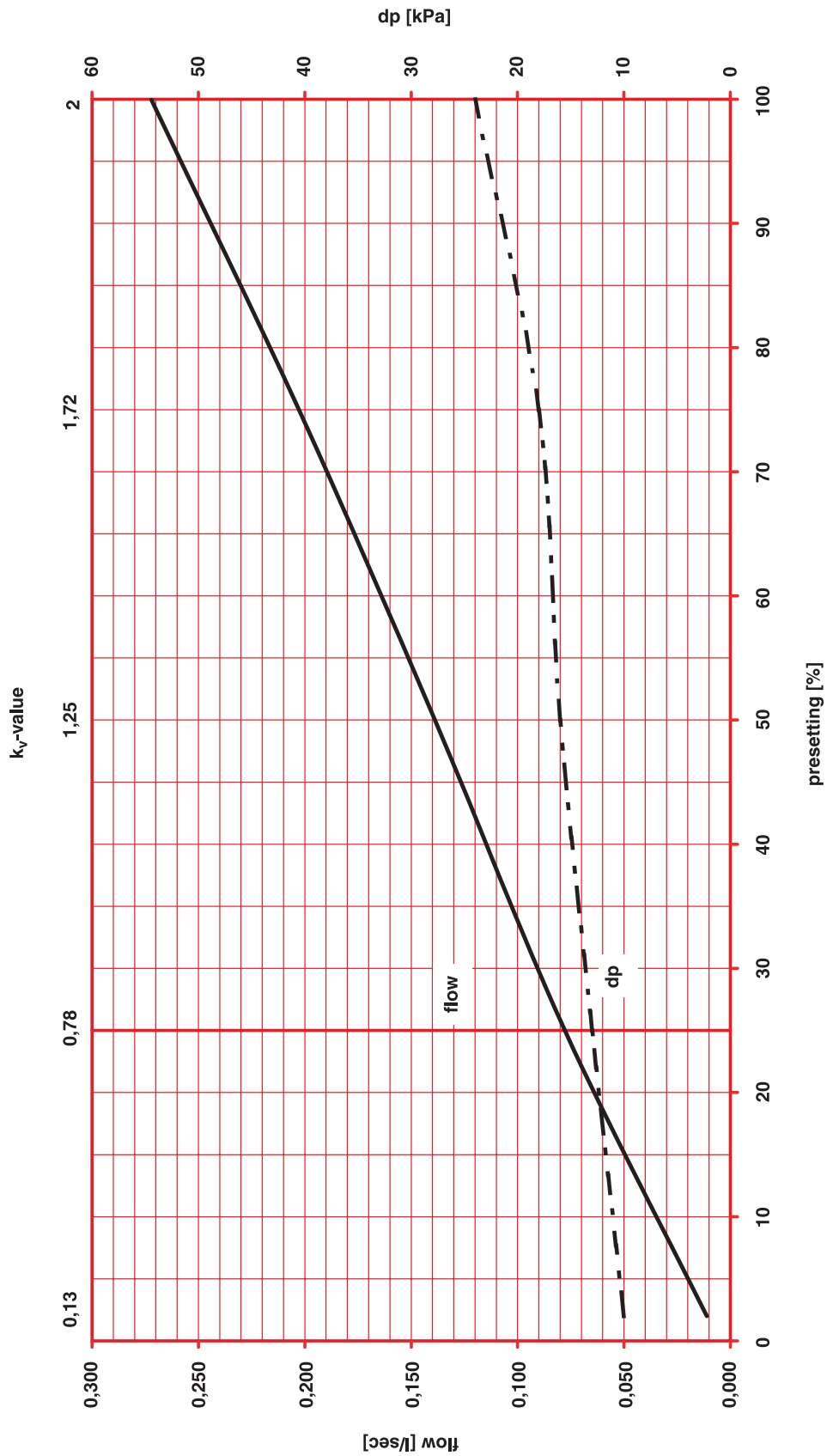

HERZ standard diagram

Order no. 1 **4001** 23, 1 **4006** 13

DN 25

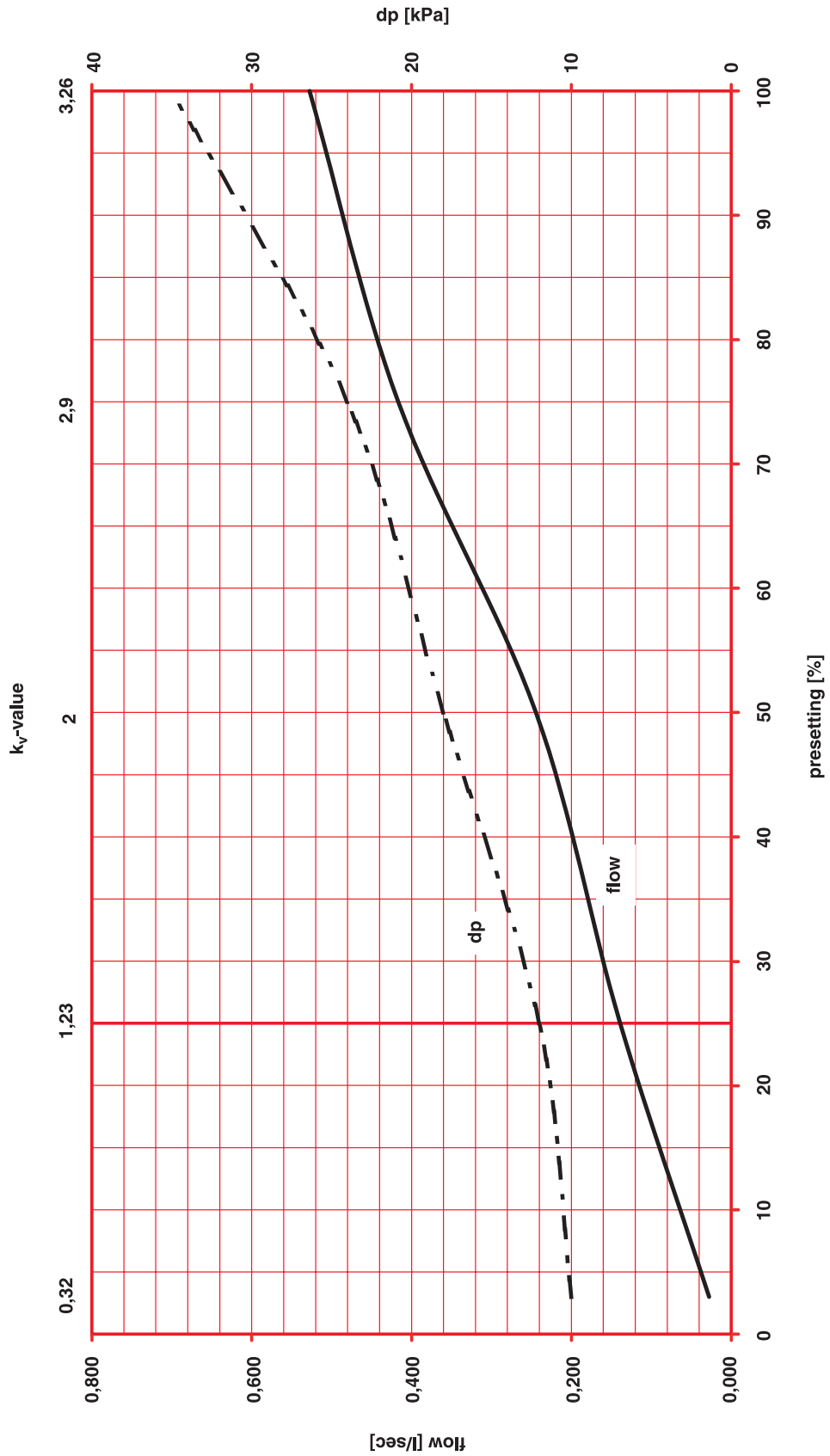

HERZ Armaturen

Richard-Strauss-Straße 22 • A-1230 Wien
 e-mail: office@herz-armaturen.com • www.herz-armaturen.com



HERZ standard diagram

Order no. 1 **4001** 24, 1 **4006** 14

DN 32

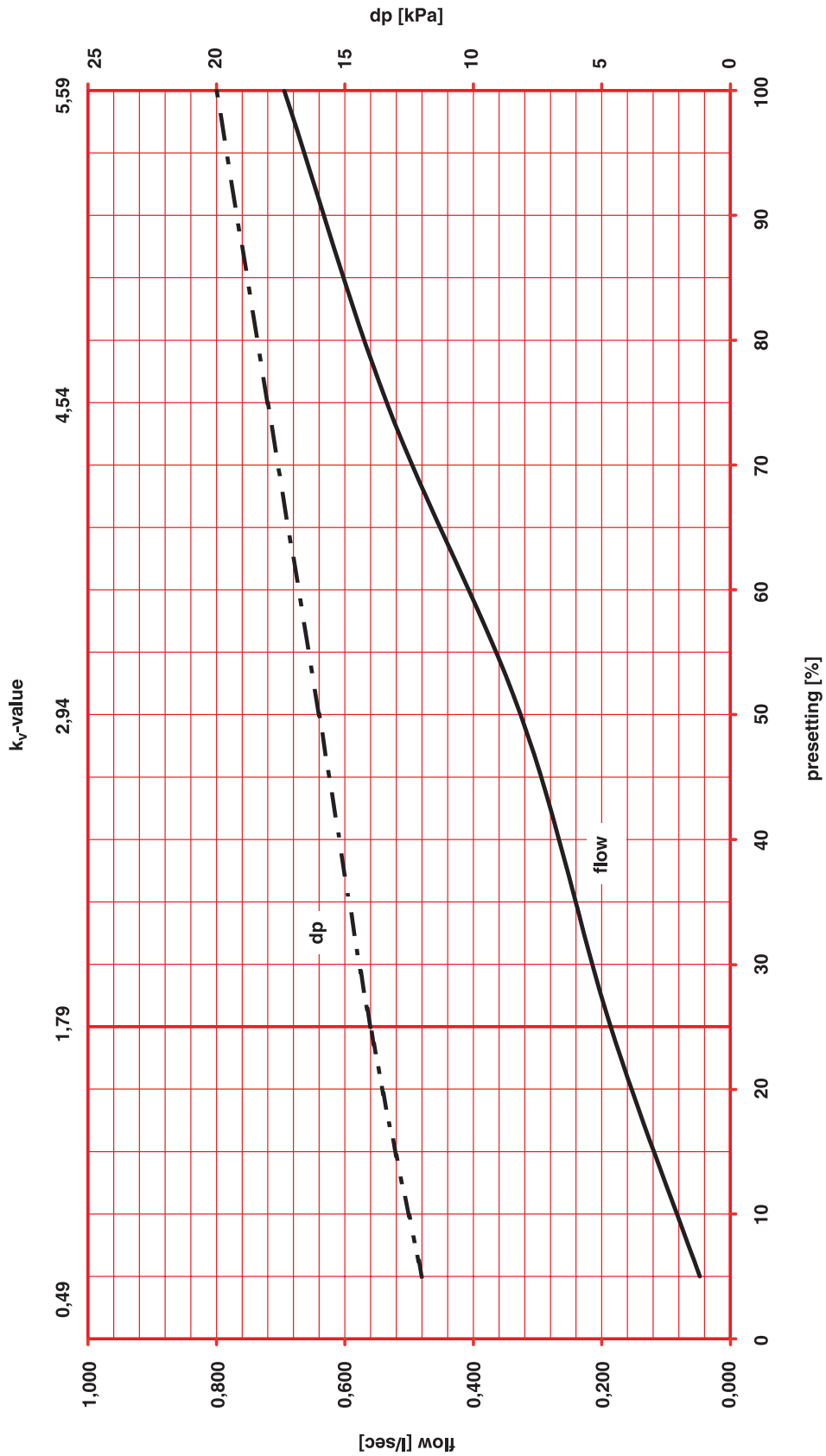

HERZ standard diagram

Order no. 1 **4001** 25, 1 **4006** 15

DN 40

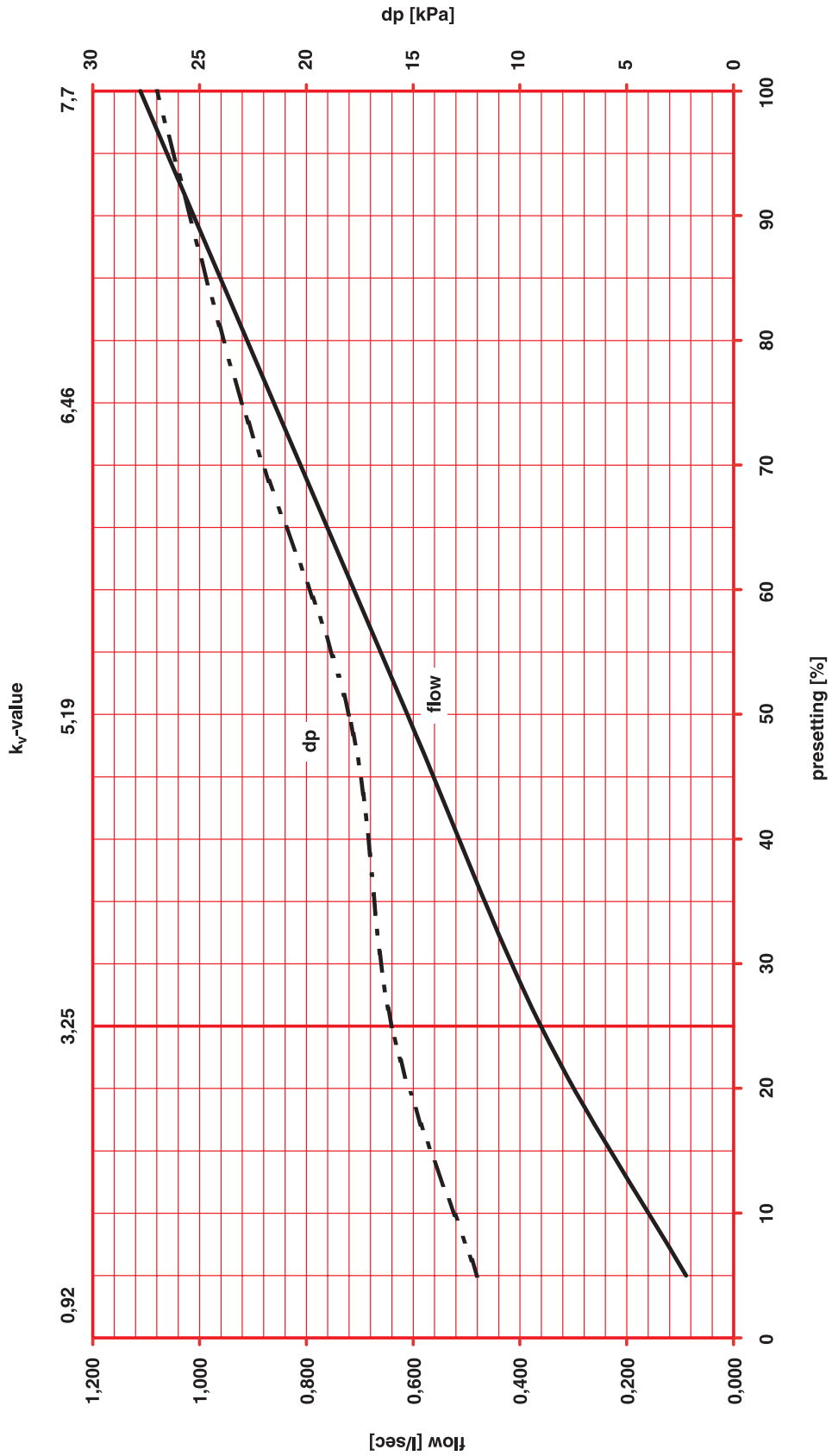

HERZ Armaturen

Richard-Strauss-Straße 22 • A-1230 Wien
 e-mail: office@herz-armaturen.com • www.herz-armaturen.com



HERZ standard diagram

Order no. 1 **4001** 26, 1 **4006** 16

DN 50

